

Cable Outlet Backshell with Pre-Installed Heat Shrink Boot



QT100 Series



The Glenair QT Series is a high performance, fast installation, environmental backshell with pre-terminated low smoke zero halogen heatshrink boot, for use with shielded or un-shielded cable. Available in a range of connector interfaces, materials/platings to match the connector and a range of cable entry sizes, these backshells can reduce installation time by up to 50% and eliminate heatshrink boot misalignment issues.

HOW TO ORDER						
Sample Part Number	QT100	H	S	15	04	ABN S
Basic Number	QT100 Banding Backshell, Shrink Boot					
Connector Designation	A, F, H, L & S					
Angular Function	S, H, or J					
Shell Size	See Table 1 & 2					
Entry Code	See Table 3					
Material / Finish	See Material and Finish Table					
Heat-Shrink Boot	S (Omit for Un-Screened Boots)					

MATERIAL AND FINISH		
Code	Material	Finish Description
ABN	Nickel Aluminium Bronze	No Plating, Degreased
BB	NES 833 Part 2 Grade 2	Vapour Blasted (Non-Reflective)
M		Electroless Nickel
NF	Aluminium Alloy B.S. 1474 6082T6	CAD Olive Drab Over Electroless Nickel
ZR		Black Zinc Nickel

TABLE 1						
Desingator		Style H		Style J		Max Entry Code
A, F & L	H	Maximum Dimensions				
		'E'	'F'	'G'	'H'	
08	09	13.0	25.0	26.0	28.5	01
10	11	14.0	25.5	27.0	30.0	02
12	13	14.5	26.0	31.0	32.0	03
14	15	15.5	26.5	37.0	33.0	04
16	17	16.0	27.5	40.0	35.0	05
18	19	16.5	28.5	45.0	36.5	05
20	21	17.0	29.0	49.0	38.0	06
22	23	17.5	30.0	52.0	38.5	06
24	25	18.0	30.0	53.0	41.0	07

- MATERIAL / FINISH NOTES**
- For Other Material/Finishes Consult Factory
 - Braid - Tinned Copper
 - Clamping Band - Stainless Steel
 - O-Ring - Silicone
 - Heat-Shrink Boot - Glenair Series 77 - Type 2

TABLE 2						
Desingator		Style H		Style J		Max Entry Code
S		Maximum Dimensions				
		'E'	'F'	'G'	'H'	
08		18.5	25.0	32.0	28.5	01
10		19.0	25.5	33.0	30.0	02
12		19.5	26.0	37.0	32.0	03
14		21.0	26.5	43.0	33.0	03
16		21.5	27.5	45.0	35.0	05
18		22.0	28.5	50.0	36.5	05
20		22.5	29.0	54.0	38.0	05
22		23.0	30.0	58.0	38.5	06
24		23.5	30.0	59.0	41.0	07

Cable Outlet Backshell with Pre-Installed Heat Shrink Boot



QT100 Series

Connector Desingator	Connector Specification	Series
A	MIL-C-5015 MIL-C-26482 MIL-C-81703 MIL-C-83723 40M39569 DEF 5326-3 LN 29504 NFC 93422 PAN 6432-1 PAN 6432-2 PATT 602 EN 2997	MS34*0 II III I & III
		HE312
F	MIL-C-38999 40M38277 NFC 93422 NFC 93422 PAN 6433-1 PATT 614 PATT 616	I & II HE309 HE308
H	MIL-C-38999 EN 3645	III & IV
L	LN 29729 NFC 93422 PAN 6433-2 PATT 615 VG 96912 EN 3372	
S	PATT 105 PATT 603 PATT 608	

TABLE 3				
Connector Desingator		Coupling Nut Data		
A	F, L & S	H	'A' Thread Ref	'B' Dia Max Standard Coupling Nut
	08		7/16-28 UNEF	16.5
		09	M12 x 1 - 6H	19.6
08			1/2-20 UNF	16.5
	10		9/16-24 UNEF	19.6
		11	M15 x 1 - 6H	20.8
10			5/8-24 UNEF	19.6
	12		11/16-24 UNEF	22.6
		13	M18 x 1 - 6H	23.9
12 (07)			3/4-20 UNEF	22.6
	14		13/16-20 UNEF	25.9
		15	M22 x 1 - 6H	27.2
14 (12)			7/8-20 UNEF	25.9
	16		15/16-20 UNEF	29.2
		17	M25 x 1 - 6H	30.7
16 (19)			1 - 20 UNEF	29.2
18 (27)	18		11/16-18 UNEF	31.2
		19	M28 x 1 - 6H	34.5
20 (37)	20		1 3/16-18 UNEF	34.5
		21	M31 x 1 - 6H	37.6
22	22		1 5/16-18 UNEF	37.6
		23	M34 x 1 - 6H	40.6
24	24		1 7/16-18 UNEF	40.6
		25	M37 x 1 - 6H	43.2
61			1 1/2-18 UNEF	42.0

TABLE 3				
Entry Code	Cable Entry Range Ø 'D'	Ø 'C'	'Y'	'Z'
01	4.5 - 9.0	7.9	60	40
02	6.0 - 12.0	12.7		
03	7.5 - 15.0	15.9	72	48
04	9.0 - 18.0	19.1		
05	10.0 - 25.0	25.4	95	55
06	12.5 - 25.0	31.8		
07	15.0 - 36.0	38.1	125	70

Cable Outlet Backshell with Pre-Installed Heat Shrink Boot



QT100 Series

Style S (Straight)

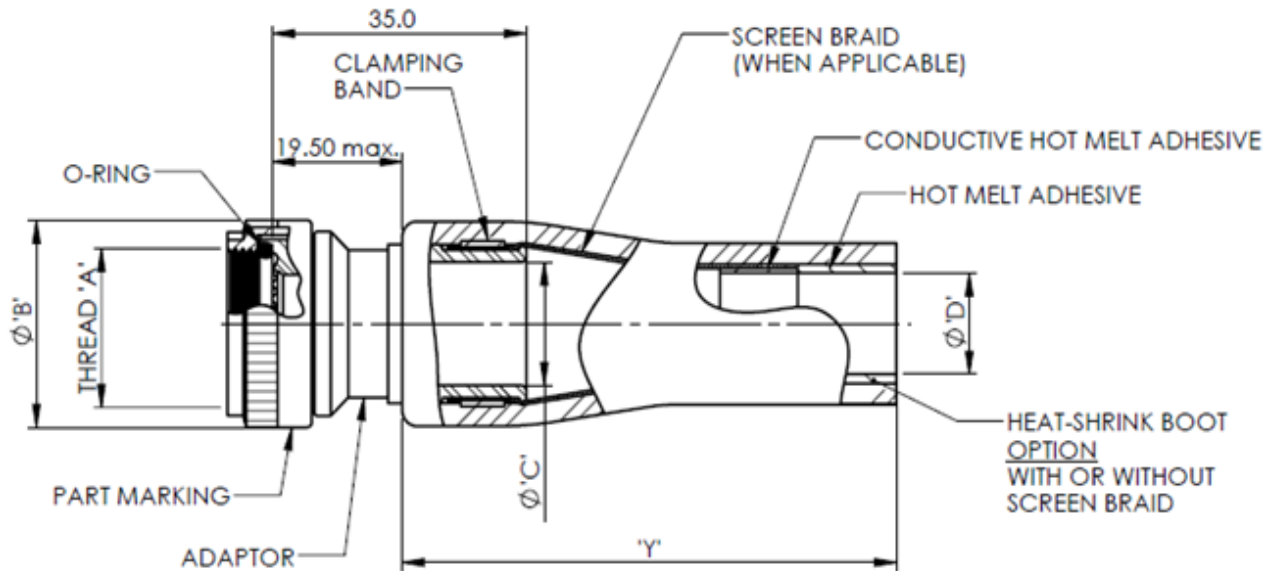

Style H (45°)

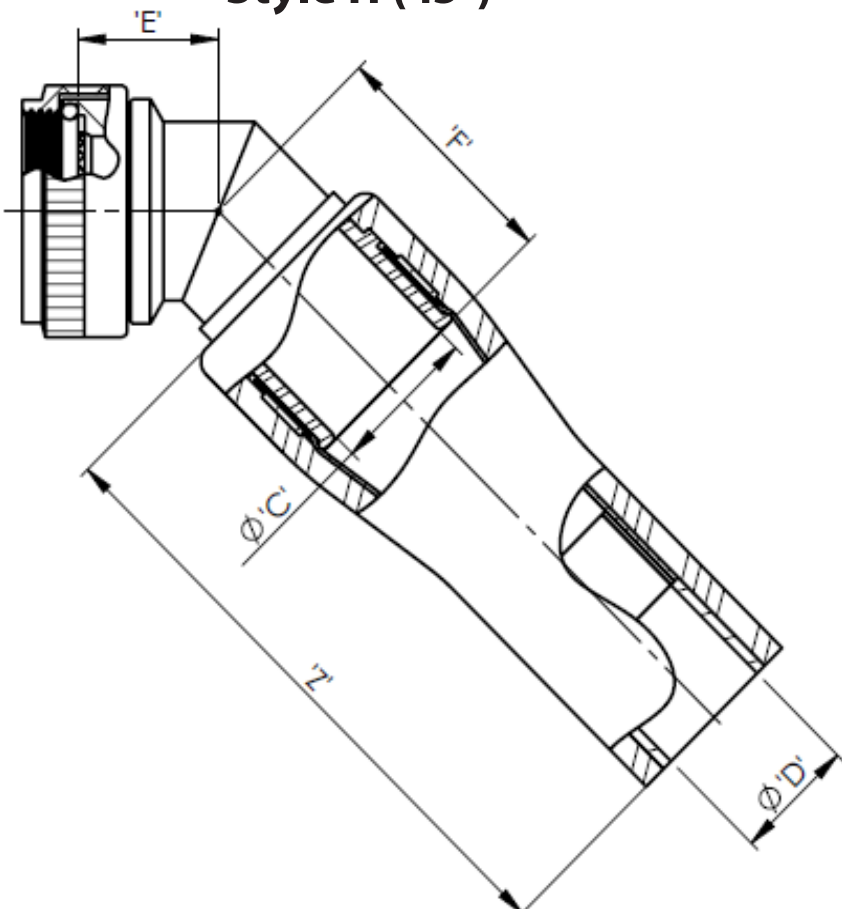

Style J (90°)

